

---

**PD1100 STAND-ALONE  
ALPHANUMERIC  
POLE DISPLAY**

---

**PROGRAMMING &  
USER'S GUIDE**



## Forward

The information contained in this user's guide is subject to change without notice.

This Programming and User's Guide was prepared by Ultimate Technology Corporation (UTC) for use by its customers, dealers, and affiliates. All attempts have been made to ensure that the information presented in this manual is correct. No liability expressed or implied, will be assumed by UTC, its dealers or affiliates for damage resulting from the use of this information.

If the dealer cannot answer your questions, please call Customer Service, Ultimate Technology: (800) 349-0546.

If a unit needs to be shipped to UTC for repairs, please return it in the original packing material and shipping container. It is recommended that one set of packing material be saved for this purpose.

**NOTE:** This equipment has been tested and found to comply with the limits for a Class "A" digital device, pursuant to Part 15 of the FCC Rules. These limits are designed to provide reasonable protection against harmful interference when the equipment is operated in a commercial environment. This equipment generates, uses, and can radiate radio frequency energy and, if not installed and used in accordance with the instruction manual, may cause harmful interference to radio communications. Operation of this equipment in a residential area is likely to cause harmful interference in which case the user will be required to correct the interference at his own expense.

## Table of Contents

<b>SECTION 1 PRODUCT INTRODUCTION</b> .....	<b>1-1</b>
Product Overview.....	1-1
General Specifications.....	1-1
Features.....	1-1
You Can Do It!.....	1-2
Using This Manual.....	1-2
Customer Support.....	1-2
<b>SECTION 2 INSTALLATION</b> .....	<b>2-1</b>
Unpacking.....	2-1
Testing.....	2-1
Mounting.....	2-1
Option One:.....	2-1
Option Two:.....	2-2
Option Three:.....	2-2
Serial Connection.....	2-3
Parallel Connection.....	2-3
Power Up.....	2-3
<b>SECTION 3 PROGRAMMING</b> .....	<b>3-1</b>
Introduction.....	3-1
Display Control.....	3-1
Dimming.....	3-1
Back Spacing.....	3-2
Horizontal Tab.....	3-2
Line Feeding.....	3-2
Carriage Return.....	3-3
Display Position.....	3-3
Normal Display Mode.....	3-3
Vertical Scroll Mode.....	3-3
Reset.....	3-3
Flashing Text Start.....	3-3
Flashing Text Stop.....	3-4
Clear to End of Line.....	3-4
Clear to End of Display.....	3-4
Home and Clear Display.....	3-4
Disable Menu Switches.....	3-4
Display Character Codes.....	3-4
<b>SECTION 4 TECHNICAL INFORMATION</b> .....	<b>4-1</b>
Cable Pinouts.....	4-1
Setup Menu.....	4-3
ASCII Character Set.....	4-4

## List of Tables

Table 3-1	Display Control Features and Commands .....	3-1
Table 3-2	Display Brightness Control Commands .....	3-2
Table 3-3	Character Position Chart (HEX).....	3-3
Table 4-1	Setup Menu and Program Parameters .....	4-3
Table 4-2	ASCII Character Set. ....	4-4

## List of Figures

Figure 2-1	Free Standing Pole Display .....	2-1
Figure 2-2	Integrated Pole Display.....	2-2
Figure 2-3	Stand Alone Pole Display .....	2-2
Figure 2-4	Inserted Pole Display .....	2-3
Figure 4-1	Typical Parallel Pinouts.....	4-1
Figure 4-2	Typical Serial Pinouts .....	4-2
Figure 4-3	Changing Setup Parameters.....	4-3

## **Section 1 PRODUCT INTRODUCTION**

### **Product Overview**

Congratulations on the purchase of your new PD1100 STAND-ALONE Pole Display. Please take a few minutes to read this section. It is designed to introduce you to your new pole display, and this User's Guide. After reading this section, you will have a better understanding of what you need to know about the PD1100 STAND-ALONE, as well as how to find the information you need.

The PD1100 STAND-ALONE is a 2 line, 20 character per line, Vacuum Fluorescent Display (VFD) unit attached to a pole-mounting base. The display unit is available in two types of interface; RS232 (serial) and Centronics (parallel). The RS232 model comes factory set for **4800 baud, 8 data bits, and no parity**.

The PD1100 STAND-ALONE was designed to connect directly to a personal computer com 1 or com 2 port, serial receipt printer with Pass Through, serial ASCII terminal auxiliary port, or any device which has a Centronics parallel port.

### **General Specifications**

Number of Characters .....	2 rows of 20 characters
Character Configuration .....	5x7 Dot Matrix
Character Set .....	ASCII
Character Height .....	10.5 mm
Character Width.....	5.5 mm
Character Pitch.....	7.4 mm
Peak Wave Length of Illumination .....	Green (505 nm)
Luminance .....	690 cd/m <sup>2</sup> (204fL)
Height .....	23"
Weight .....	2.50 lbs.
Width .....	8.75"
Depth .....	1.80"
Operating Temperature .....	0 to 50 degrees C
Storage Temperature .....	-20 to +70 degrees C
Relative Humidity.....	90% Non-Condensing
Power Requirements .....	+9 VDC @ 1.2 amp

### **Features**

- 2 Line – 20 Character/Line Vacuum Fluorescent Display
- 10.5 mm Character Height
- 5 x 7 Dot Matrix

- RS232 Serial or Parallel Interface
- 360 Degree Rotation
- 10 Degree Bi-directional Tilt
- Menu Driven Setup
- 16 Selectable Baud Rates
- 4 Programmable Display Intensities
- Flashing Text
- Vertical Scrolling
- Non-volatile Parameter Storage

### **You Can Do It!**

The PD1100 STAND-ALONE Pole Display is easy to set up and install by following the instructions in this manual. No special training or tools are necessary.

### **Using This Manual**

This Programming and User's Guide contains information on the installation and programming of your PD1100 STAND-ALONE Pole Display. It is suggested that the entire manual be read before attempting installation or programming.

### **Customer Support**

If you are unable to resolve a problem after reading and reviewing this manual, contact Customer Service:

Ultimate Technology Corporation  
100 Rawson Road  
Victor, New York 14564  
Phone: (800) 349-0546  
Fax: (585) 924-1434

## **Section 2**    **INSTALLATION**

### **Unpacking**

The PD1100 STAND-ALONE is shipped in a strong, lightweight cardboard container. The components are packed in foam padding which protects them during shipping.

**Note:** Check packaging for water or physical damage and notify your carrier immediately if any damage is evident. Carefully remove the components from the box. Keep original packing material in the event that the PD1100 STAND-ALONE needs to be shipped to another location.

### **Testing**

A diskette has been provided for testing your PD1100 STAND-ALONE. To test the PD1100 STAND-ALONE using the provided test program, a DOS-based PC will be required. The diskette contains a "README" file with instructions on running the test program.

### **Mounting**

The PD1100 STAND-ALONE comes with a mounting device, consisting of a mounting bracket and mounting plate. The mounting device can be utilized in a variety of ways. Review the following options and select the option that best suits your application.

**Note:** Before proceeding any further, be sure that the computer terminal or device you are connecting to is powered off. To ensure a power-off state, remove the device from its power source.

#### Option One:

This option, shown in Figure 2-1, allows the user to place the pole display, with mounting bracket and plate attached, under a cash drawer, register unit or computer terminal.

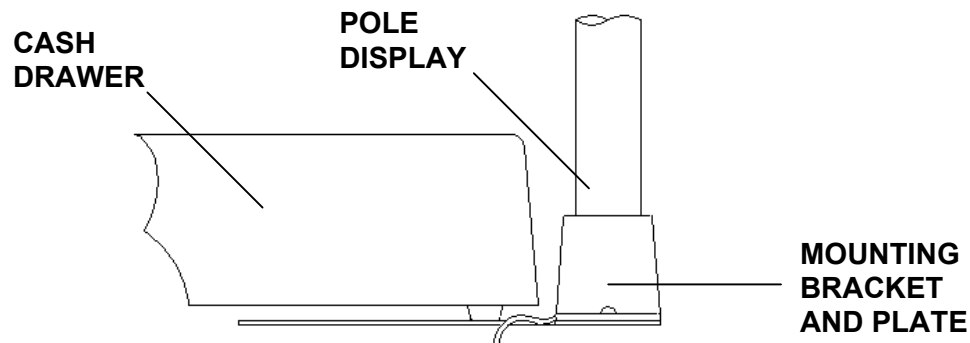

Figure 2-1    Free Standing Pole Display

Option Two:

This option, shown in Figure 2-2, allows the user to install the pole display directly inside the UTC 5253 POS Terminal. Should you choose this option, the mounting plate is removed, and only the mounting bracket is installed inside the left rear of the UTC 5253 enclosure.

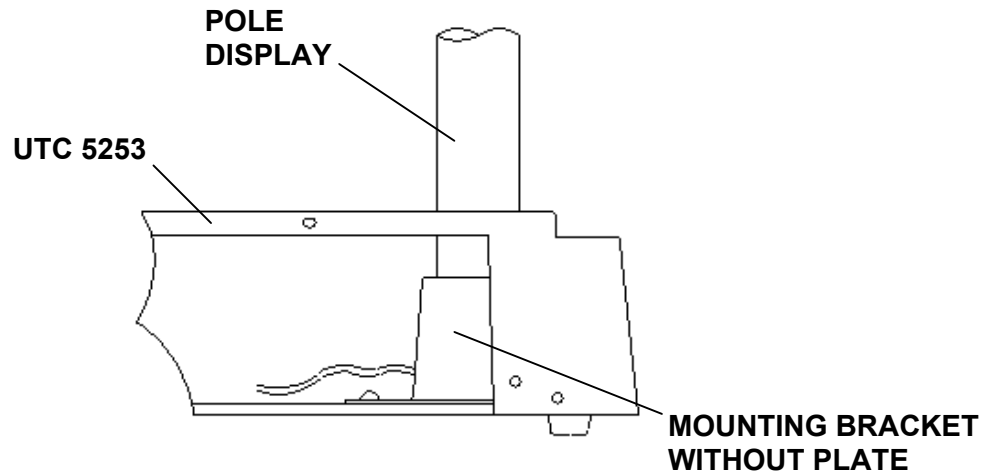

Figure 2-2 Integrated Pole Display

Option Three:

This option, shown in Figure 2-3, allows the user to install the pole display in a variety of ways. You may choose to install the display unit using just the mounting bracket, or with the mounting bracket attached to the center or other position on the mounting plate.

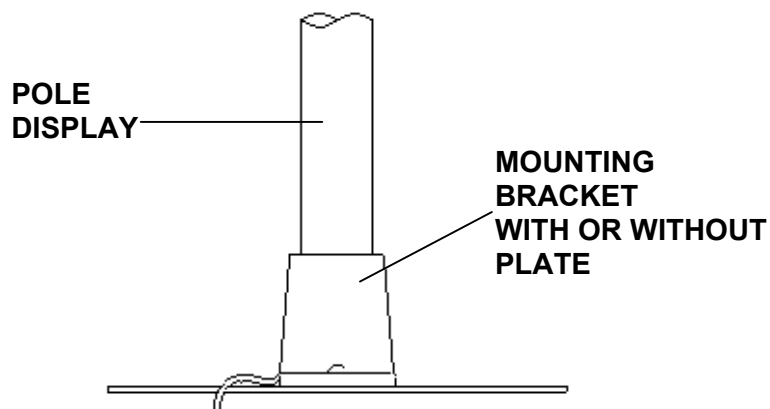

Figure 2-3 Stand Alone Pole Display



After determining which option best suits your needs, begin the installation. Insert the interface cable, which comes out of the bottom of the PD1100 STAND-ALONE pole display, through the top of the mounting bracket.

**Note:** Avoid placing pressure of any kind on the display head.

Holding the pole, insert the pole into the mounting bracket using a back and forth twisting motion to ensure a secure fit. Ensure that the cable(s) clear all obstructions while inserting the pole into mounting bracket. The pole should be inserted until it reaches the bottom stop. The stop, as shown in Figure 2-4, is located  $\frac{1}{4}$ " from the bottom of the bracket.

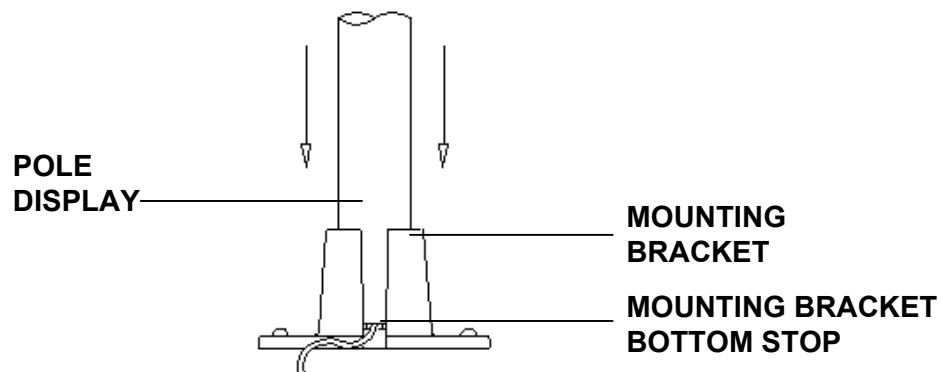

Figure 2-4 Inserted Pole Display

### Serial Connection

Attach the round 6 pin DIN male connector coming from the PD1100 STAND-ALONE to the round 6 pin female connector of the cable provided. Plug the rectangular DB9 or the DB25 connector into your computer or communicating device. Now you are ready to perform the Power-Up procedure.

### Parallel Connection

Plug the rectangular DB25 connector into the parallel port of your computer or communicating device. Now you are ready to perform the Power-Up procedure.

### Power-Up

Plug the barrel type connectors at the ends of the black power wire and the wall transformer wire together. Place the wall transformer into a 120-volt AC power source. The display unit will momentarily display Ultimate Technology ROM version.

## Section 3 PROGRAMMING

### Introduction

The PD1100 STAND-ALONE Pole Display operates by converting recognized data, supplied by a communicating device, into a display message. The supplied data may also contain commands that control the display.

The PD1100 STAND-ALONE uses a limited command structure for display control, requiring minimal programming effort. Table 3-1 lists the display control features of the PD1100 STAND-ALONE and control codes (in ASCII, DEC, and HEX expression). The display control command structure, with examples, is described in this section.

Table 3-1 Display Control Features and Commands.

	FEATURE	ASCII	DEC	HEX
(1)	Dimming	<EOT>x	4, x	04, xx
(2)	Back Space	<BS>	8	08
(3)	Horizontal Tab	<HT>	9	09
(4)	Line Feed	<LF>	10	0A
(5)	Carriage Return	<CR>	13	0D
(6)	Display Position	<DLE>p	16,p	10,pp
(7)	Normal Display	<DC1>	17	11
(8)	Vertical Scrolling	<DC2>	18	12
(9)	Reset	<US>	31	1F
(10)	Flashing Text Start	<FS>	28	1C
(11)	Flashing Text Stop	<GS>	29	1D
(12)	Clear to End of Line	<CAN>	24	18
(13)	Clear to End of Display	<EM>	25	19
(14)	Home and Clear Display	<RS>	30	1E
(15)	Disable Menu Switches	<NAK>	21	15

### Display Control

The following describes all display control features along with an example of their command and data sequence.

#### 1. Dimming <EOT>x 04 DEC 04 HEX

Upon receipt of a dimming command, subsequent characters will be at the brightness level selected. This level will remain until a new dimming command is received. Where x is the option byte:

x	=	Dim	Low	Medium	High
		20h	40h	60h	FFh

Table 3-2 Display Brightness Control Commands

Dimming Level	ASCII	DEC	HEX
100 %	-	255	FF
60 %	`	96	60
40 %	@	64	40
20 %	Space	32	20

**2. Back Spacing                    <BS>                    08 DEC                    08 HEX**

When the backspace command is executed, the write-in position is shifted to the left one position, erasing the character, if any, in that position. When the write-in position is in the first (read from left to right) position of the first row, the write-in moves to the last position of the second row. When the write-in is in the first position of the second row, the write-in moves to the last position of the first row.

**3. Horizontal Tab                    <HT>                    09 DEC                    09 HEX**

DC1 Mode  
(Normal Display Mode)

The write-in position is shifted to the right one position. When the write-in is in the last position of the first row, the write-in moves to the first position of the second row. When the write-in is in the last position of the second row, the write-in moves to the first position of the first row.

DC2 Mode  
(Vertical Display Mode)

When the write-in is in the last position of the second row, the characters displayed in the second row are shifted up to the first row and the write-in moves to the first position of the second row. This action clears the second row.

**4. Line Feeding                    <LF>                    10 DEC                    0A HEX**

DC1 Mode  
(Normal Display Mode)

The write-in moves up or down to another row, staying in the same horizontal position.

DC2 Mode  
(Vertical Display Mode)

When the write-in is in the second row, the characters displayed there are shifted up to the first row, leaving the write-in at its present

position. This action clears the second row. When the write-in is in the first row, the write-in moves down to the second row.

- 5. Carriage Return <CR> 13 DEC 0D HEX**

The write-in moves to the first position of the same row.

- 6. Display Position <DLE> 16 DEC 10 HEX**

After writing the <DLE> character to the display it waits for a position byte from the following chart.

Table 3-3 Character Position Chart (HEX)

**ROW**

1	00	01	02	03	04	05	06	07	08	09	0A	0B	0C	0D	0E	0F	10	11	12	13
2	14	15	16	17	18	19	1A	1B	1C	1D	1E	1F	20	21	22	23	24	25	26	27

- 7. Normal Display Mode <DC1> 17 DEC 11 HEX**

After writing a character, the write-in is shifted automatically to the right one position. When the write-in is in the last position of the first row, the write-in moves to the first position of the second row. When the write-in is in the last position of the second row, the write-in moves to the first position of the first row.

- 8. Vertical Scroll Mode <DC2> 18 DEC 12 HEX**

After writing the characters up to the last position of the second row, all characters displayed in the second row are shifted to the upper row (first row), clearing the second row.

- 9. Reset <US> 31 DEC 1F HEX**

All characters displayed are erased and the write-in position (cursor position) is set in the first position of the first row. The display status returns to the power-on default set-up.

- 10. Flashing Text Start <FS> 28 DEC 1C HEX**

After receipt of this command all subsequent data received will flash, until a <GS> command is received. Flashing will be terminated with the stop flashing command.

- 11. Flashing Text Stop <GS> 29 DEC 1D HEX**

After receipt of this command the characters following will not flash.

- 12. Clear to End of Line <CAN> 24 DEC 18 HEX**

This command will clear out the display from the current write-in position to the end of the current line. The current write-in position will not change.

- 13. Clear to End of Display <EM> 25 DEC 19 HEX**

This command will clear out the display from the current write-in position to the end of the second line. The current write-in position will not change.

- 14. Home and Clear Display <RS> 30 DEC 1E HEX**

This command will clear the display and move the write-in position to the first position of the first row.

- 15. Disable Menu Switches <NAK> 21 DEC 15 HEX**

Upon receipt of this command the menu buttons will be disabled until next power up.

### **Display Character Codes**

Refer to ASCII Character Set on page 4-4 for a full listing of the display character codes used by the PD1100 STAND-ALONE.

## **Section 4 TECHNICAL INFORMATION**

### **Cable Pinouts**

The PD1100 STAND-ALONE Pole Display cable connections can be configured to user specifications. Figures 4-1 and 4-2 show typical parallel and RS232 (serial) pinout data.

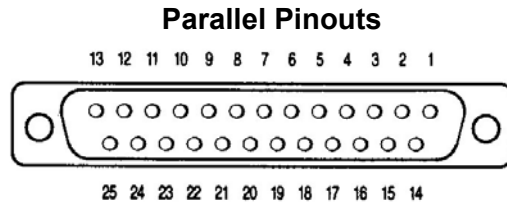

### **DB25 Male**

1	Strobe	10	ACK
2	Data 0	11	Busy
3	Data 1	12	Paper End (Low)
4	Data 2	13	Select (High)
5	Data 3	14-17	N/C
6	Data 4	15	Error (High)
7	Data 5	16	Initialize
8	Data 6	18-24	Signal Ground
9	Data 7	25	N/C

Figure 4-1 Typical Parallel Pinouts.

## RS232 Pinouts

### DB9 FEMALE

- 3 Receive Data
- 4
- 8
- 5 Signal Ground
- 7
- 8

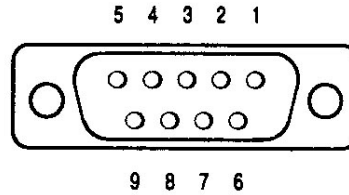

### DB25 FEMALE

- 1 Frame Ground
- 2 Receive Data
- 4 Add Lines Here
- 5 Add Lines Here
- 7 Signal Ground
- 6 Add Lines Here
- 8 Add Lines Here
- 20 Add Lines Here

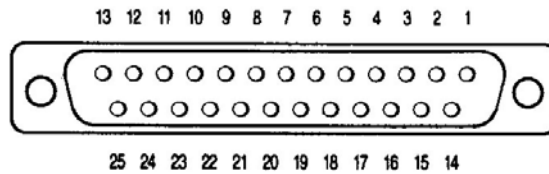

### 6 PIN DIN MALE

- 1 +9 VDC
- 2
- 3 Signal Ground
- 4 GND
- 5 Receive Data
- 6 +5 VDC @ 1.2 amp

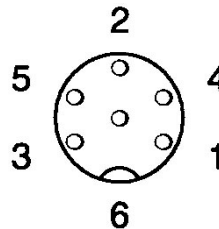

Figure 4-2 Typical Serial Pinouts

## Setup Menu (Serial version of PD1100 STAND-ALONE only)

To enter the setup mode, depress (and release) both menu buttons simultaneously. The first menu parameter will appear on the display. Depressing the left button will advance to the next selection within that parameter. Stopping on a particular selection will activate that selection. Depressing the right button will advance the display to the next menu parameter.

Table 4-1 Setup Menu and Program Parameters

MENU ITEMS	OPTIONS
* 1. RESET DEFAULTS	YES, NO **
2. BAUD RATE	300, 600,900,1200,1800,2400,2800, 3600,4800**, 6400,7200,9600,14.4k, 19.2k, 28.8k, 57.6k BPS
3. PARITY	NONE **, EVEN, ODD, MARK, SPACE
* 4. BRIGHTNESS	DIM, LOW, MEDIUM, HIGH **
* 5. POWER UP MODE	WRAP (DC1), NO WRAP (DC2) **
* 6. SAVE CHANGES NOW?	YES, NO **
* 7. EXIT SETUP NOW?	YES **, NO

\*Setup Menu items for parallel version.

\*\* Default setting for each menu item in non-volatile memory.

NOTE: Baud rates over 9600 may lose characters if an inter character delay is not used

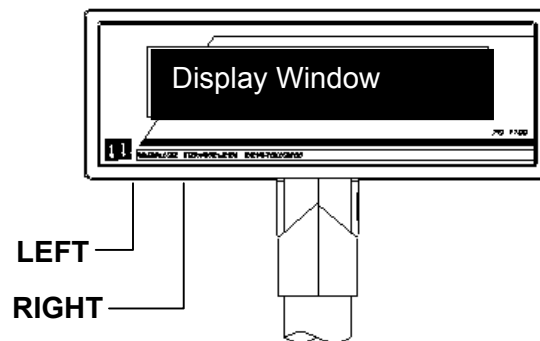

Figure 4-3 Changing Setup Parameters



## ASCII Character Set

Table 4-2 ASCII Character Set.

DEC	HEX	ASCII	DEC	HEX	ASCII	DEC	HEX	ASCII	DEC	HEX	ASCII
0	00	Ctrl-@ (NUL)	32	20	Space	64	40	@	96	60	`
1	01	Ctrl-A (SOH)	33	21	!	65	41	A	97	61	a
2	02	Ctrl-B (STX)	34	22	"	66	42	B	98	62	b
3	03	Ctrl-C (ETX)	35	23	#	67	43	C	99	63	c
4	04	Ctrl-D (EOT)	36	24	\$	68	44	D	100	64	d
5	05	Ctrl-E (ENQ)	37	25	%	69	45	E	101	65	e
6	06	Ctrl-F (ACK)	38	26	&	70	46	F	102	66	f
7	07	Ctrl-G (BEL)	39	27	'	71	47	G	103	67	g
8	08	Ctrl-H (BS)	40	28	(	72	48	H	104	68	h
9	09	Ctrl-I (HT)	41	29	)	73	49	I	105	69	i
10	0A	Ctrl-J (LF)	42	2A	*	74	4A	J	106	6A	j
11	0B	Ctrl-K (VT)	43	2B	+	75	4B	K	107	6B	k
12	0C	Ctrl-L (FF)	44	2C	,	76	4C	L	108	6C	l
13	0D	Ctrl-M (CR)	45	2D	-	77	4D	M	109	6D	m
14	0E	Ctrl-N (SO)	46	2E	.	78	4E	N	110	6E	n
15	0F	Ctrl-O (SI)	47	2F	/	79	4F	O	111	6F	o
16	10	Ctrl-P (DLE)	48	30	0	80	50	P	112	70	p
17	11	Ctrl-Q (DC1)	49	31	1	81	51	Q	113	71	q
18	12	Ctrl-R (DC2)	50	32	2	82	52	R	114	72	r
19	13	Ctrl-S (DC3)	51	33	3	83	53	S	115	73	s
20	14	Ctrl-T (DC4)	52	34	4	84	54	T	116	74	t
21	15	Ctrl-U (NAK)	53	35	5	85	55	U	117	75	u
22	16	Ctrl-V (SYN)	54	36	6	86	56	V	118	76	v
23	17	Ctrl-W (ETB)	55	37	7	87	57	W	119	77	w
24	18	Ctrl-X (CAN)	56	38	8	88	58	X	120	78	x
25	19	Ctrl-Y (EM)	57	39	9	89	59	Y	121	79	y
26	1A	Ctrl-Z (SUB)	58	3A	:	90	5A	Z	122	7A	z
27	1B	Ctrl-[ (ESC)	59	3B	;	91	5B	[	123	7B	{
28	1C	Ctrl-\ (FS)	60	3C	<	92	5C	\	124	7C	
29	1D	Ctrl-] (GS)	61	3D	=	93	5D	]	125	7D	}
30	1E	Ctrl-^ (RS)	62	3E	>	94	5E	^	126	7E	~
31	1F	Ctrl-_ (US)	63	3F	?	95	5F	_	127	7F	DEL